



Series ES-11 CE Marked Single Phase Transformers

DONGAN ELECTRIC MANUFACTURING CO. • 2987 FRANKLIN • DETROIT, MI 48207
 800.428.2626 • 313.567.8500 • FAX 313.567.8828 • www.dongan.com

Series ES Single Phase Encapsulated Transformers are designed to comply with Domestic, North American, and European Union electrical and testing standards. Series ES are UL and Canadian UL Listed by Underwriters Labs. In addition, Series ES are CE Marked, and licensed by the German testing agency TÜV Rheinland under License Number R 9679035.01.

Series ES transformers are the answer to your export needs. With the voltage combinations listed below, and built in approvals, the ES Series provide no-nonsense solutions for equipment destined for the European Community of nations.

Under EC guidelines, connecting transformers to line and load require finger safe connections. While other manufacturers provide leads, Dongan provides finger safe terminals on all ES-11 transformers. This feature eliminates the necessity of a difficult, labor intensive installation of terminals in the wiring compartment by the end user.

The voltage combinations offered represent some of the most universally used. However, any combination of primary and secondary incorporating voltages of 600 volts and below is available on a short lead time, special order basis. In addition, capacities up to 25 kVA and special temperature rise configurations can be

furnished. Please consult your distributor, Dongan Representative, or the factory for special ES Series transformer requirements.

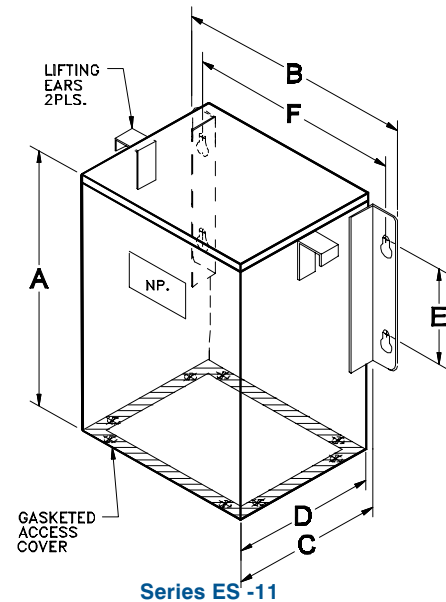

General Information									
Pri. Volts	380/400/416/440	220/380/400/416	Dimensions (inches)						Weight (lbs)
Sec. Volts	460/480/575	120/240	A	B	C	Mounting			
kVA Cap.	Catalog Number	Catalog Number				D	E	F	
.250	ES-11130.326	ES-11130.359	10.50	10.00	6.62	6.12	4.00	8.50	35
.500	ES-11170.326	ES-11170.359	10.50	10.00	6.62	6.12	4.00	8.50	45
.750	ES-11190.326	ES-11190.359	10.50	10.00	6.62	6.12	4.00	8.50	55
1.0	ES-11200.326	ES-11200.359	12.00	10.81	7.19	6.69	6.00	9.13	75
1.5	ES-11210.326	ES-11210.359	14.00	14.00	9.25	8.75	8.00	12.00	90
2.0	ES-11230.326	ES-11230.359	14.00	14.00	9.25	8.75	8.00	12.00	110
3.0	ES-11250.326	ES-11250.359	14.00	14.00	9.25	8.75	8.00	12.00	120
5.0	ES-11300.326	ES-11300.359	14.00	14.38	10.00	9.50	8.00	12.38	150
7.5	ES-11330.326	ES-11330.359	15.00	18.00	12.50	12.00	8.00	16.00	165
10.0	ES-11360.326	ES-11360.359	15.00	18.00	12.50	12.00	8.00	16.00	190
15.0	ES-11380.326	ES-11380.359	15.00	18.00	12.50	12.00	8.00	16.00	270
25.0	ES-11410.326	ES-11410.359	18.00	21.00	10.50	10.00	8.00	19.00	350

Series ES-11 CE Marked Single Phase Transformers

Features

- CE Marked
- TÜV Rheinland Licensed, R 9679035.01
- UL Listed, File E3210.
- CSA Listed thru UL, File E3210
- NEMA 12, IP54 enclosure.
- All copper windings.
- IEC type finger safe terminals.
- 200°C (H) Insulation System.
- 50/60 Hertz.
- Class 1, general use, isolating transformer.
- All Series ES are provided with an electrostatic shield (earth metal screen).
- All Series ES are provided with a color coded protective earth (PE) terminal.
- Consult factory for desired voltage combinations and KVA sizes not listed.

Agency Compliance



Series ES Three Phase and Industrial Control Transformers

Please see Series ES CE Marked Three Phase on pages 36 - 37 and Industrial Control transformers on pages 82 - 83 of this catalog. A Declaration of Conformity is available by contacting your Dongan Representative or the factory Customer Service Department.

Dimensions & weights may change. Consult factory for certified drawings.

Suffix .326			
Primary Connections		Secondary Connections	
Pri. Voltage	Connect Incoming Lines To:	Sec. Voltage	Connect Load Lines To:
380	H1 & H3	110	X1 & X3
400	H1 & H3	115	X1 & X3
416	H1 & H4	115	X1 & X4
440	H1 & H4	120	X1 & X4
460	H1 & H4	115	X1 & X3
480	H1 & H4	120	X1 & X3
575	H1 & H5	120	X1 & X4

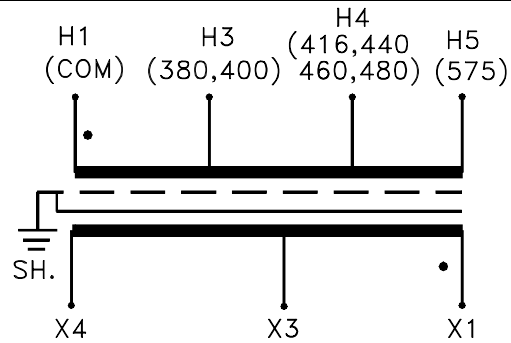

Suffix .359				
Primary Connections		Secondary Connections		
Pri. Voltage	Connect Incoming Lines To:	Sec. Voltage	Interconnect	Connect Load Lines To:
220	H1 & H3	120	X1 to X3 X2 to X4	X1 & X4
380	H1 & H4	240	X2 to X3	X1 & X4
400	H1 & H5	120/240	X2 to X3	X1 & X2X3 & X4
416	H1 & H6			

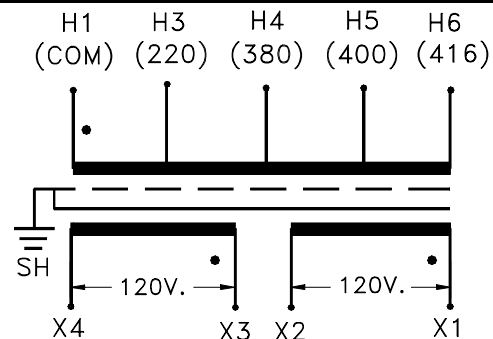

DONGAN ELECTRIC MANUFACTURING CO. • 2987 FRANKLIN • DETROIT, MI 48207
 800.428.2626 • 313.567.8500 • FAX 313.567.8828 • www.dongan.com