

K-Factor Transformers for Harmonic Loads

DONGAN ELECTRIC MANUFACTURING Co. • 2987 FRANKLIN • DETROIT, MI 48207
 800.428.2626 • 313.567.8500 • FAX 313.567.8828 • www.dongan.com

Domestic distribution systems and linear loads operate at the fundamental frequency of 60 Hz. Harmonic content in distribution systems means that there are integer multipliers of the fundamental 60 Hz frequency present. For instance, the second harmonic is 120 Hz, the third harmonic is 180 Hz, the fourth harmonic is 240 Hz, etc.

Traditionally, linear transformer loads exhibit voltage and current typically at the fundamental frequency and generally have little harmonic content. Nonlinear transformer loads, on the other hand, introduce significant harmonics into a distribution system. Harmonics are created due to the method in which nonlinear devices draw current in pulses at the voltage peak of the AC sine wave waveform.

Transformers operating in a distribution system containing significant harmonics will exhibit potentially serious effects of increased operating temperature. Additionally, it is common to find overloaded neutral conductors resulting from the additive effect of third harmonic and succeeding odd multiple harmonic current flow (triplen harmonics) as well as circulating currents in the primary, eddy current losses, and skin effect losses.

Nonlinear loads should be suspected where there is a presence of switch mode power supplies commonly found in desktop personal computers, printers, mainframes, and other electronic equipment. Other sources include electronic ballasts, variable speed AC motor drives, certain fluorescent lighting fixtures, and some types of welders. As existing distribution systems have these types of devices installed, harmonic problems multiply!

Harmonic content of a distribution system is indicated by a number called K-Factor. Larger



values of “K” indicate the presence of more harmonics in the load. Harmonic content of a load may be determined by measurement utilizing a recording analyzing meter. Linear loads have a K-Factor of 1. Switch mode power supplies have a K-Factor as high as K-20. Other nonlinear loads have a K-Factor which varies with the device.

Dongan K-Factor transformers are specifically engineered to operate at full load and full harmonic rating without exceeding the rated insulation system values - effectively neutralizing the dangerous effects of temperature and circulating currents. Windings and cores are designed to operate in the presence of triplen harmonics without overheating or forcing the core into saturation. These transformers will provide years of trouble free service to large office buildings, industrial plants, processing equipment and any load with a designated harmonic content.

K - 4, Primary 480 Volts Delta, Secondary 208Y / 120, 60 Hz

General Information			Winding Specifications			Dimensions		
kVA Cap.	Catalog Number	Wgt. Lbs	Taps	Maximum Amps		Height A	Width B	Depth C
				Pri. 480	Sec. 208Y/120			
15.0	TK04-6315SH	280	6	18.0	41.6	23.50	18.88	18.50
30.0	TK04-6330SH	350	6	36.1	83.0	29.00	24.25	20.88
45.0	TK04-6345SH	550	6	54.0	125.0	29.00	24.25	20.88
75.0	TK04-6375SH	860	6	90.0	208.0	32.00	27.25	26.25
112.5	TK04-63112SH	1100	6	135.0	312.0	41.00	34.25	26.75
150.0	TK04-63150SH	1320	6	180.0	416.0	41.00	34.25	26.75

Connection Diagrams may be found on Pg. 41

Tap Configurations:

0 = No Taps
 2 = 1 - 5% FCAN, 1 - 5% FCBN
 4 = 2 - 2½% FCAN, 2 - 2½% FCBN
 6 = 2 - 2½% FCAN, 4 - 2½% FCBN

Dimensions & weights may change. Consult factory for certified drawings.

K-Factor Transformers for Harmonic Loads

Features

- **UL Recognized Insulation System File E100887.**
- **Three Phase: 15 - 150 kVA**
- **Electrostatic shield** between windings provides cleaner output voltage and helps to reduce spikes and transients.
- **Aluminum windings** connect to bus bar style terminations equipped with NEMA standard holes for compression style terminals.
- **UL Class 220°C insulation system** with 150°C

- temperature rise at full load and rated ambient.
- **NEMA-3R**, ventilated, cabinet style, floor mount enclosure suitable for indoor or outdoor use. *No extra rainshields required for outdoor use.*
- **Vibration dampening pads** provide quiet operation.
- **Wall Mounting brackets** are available in sizes up to 75 kVA (See pg. 29).
- **Ground studs** provided for bonding compatibility with both metallic and nonmetallic conduit.
- **Nonstandard designs** are available by consulting the factory or your Dongan representative.

K - 13, Primary 480 Volts Delta, Secondary 208Y / 120, 60 Hz

General Information			Winding Specifications			Dimensions		
kVA Cap.	Catalog Number	Wgt. Lbs	Taps	Maximum Amps		Height A	Width B	Depth C
				Pri. 480	Sec. 208Y/120			
15.0	TK13-6315SH	300	6	18.0	41.6	29.00	24.25	20.88
30.0	TK13-6330SH	450	6	36.1	83.0	29.00	24.25	20.88
45.0	TK13-6345SH	600	6	54.0	125.0	32.00	27.25	26.25
75.0	TK13-6375SH	950	6	90.0	208.0	41.00	34.25	26.75
112.5	TK13-63112SH	1200	6	135.0	312.0	41.00	34.25	26.75
150.0	TK13-63150SH	1400	6	180.0	416.0	41.00	34.25	26.75

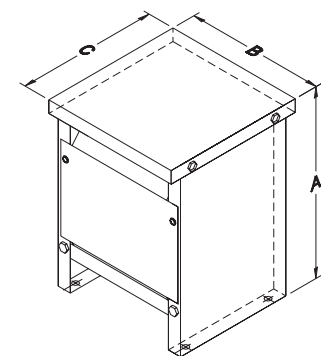

15 - 150 kVA
Floor Mount - Ventilated - NEMA 3R

K - 20, Primary 480 Volts Delta, Secondary 208Y / 120, 60 Hz

General Information			Winding Specifications			Dimensions		
kVA Cap.	Catalog Number	Wgt. Lbs	Taps	Maximum Amps		Height A	Width B	Depth C
				Pri. 480	Sec. 208Y/120			
15.0	TK20-6315SH	350	6	18.0	41.6	29.00	24.25	20.88
30.0	TK20-6330SH	550	6	36.1	83.0	29.00	24.25	20.88
45.0	TK20-6345SH	650	6	54.0	125.0	32.00	27.25	26.25
75.0	TK20-6375SH	1000	6	90.0	208.0	41.00	34.25	26.75
112.5	TK20-63112SH	1300	6	135.0	312.0	41.00	34.25	26.75
150.0	TK20-63150SH	1700	6	180.0	416.0	44.00	48.00	30.00

